



**AKYOLSAN MACHINERY
DOMESTIC AND FOREIGN TRADE JOINT STOCK COMPANY**



AKYOLSAN MAKİNA & VE D. TİCARET A.Ş.

-THE ONLY ADDRESS OF QUALITY-

The Family Spirit and Promise of Belonging, which dates back to the establishment of the company, lives on in every AKYOLSAN MAKİNA Employee. Accuracy and Honesty are Priority Values in All Business Processes and Relationships. AKYOLSAN MAKİNA Acts with Integrity and Honesty in Its Relationships with Its Employees and II Its Stakeholders.



ALL AROUND THE WORLD



CHOOSING AND PACKING CHERRIES



KIRAZ MACHINE SPARE PARTS

CHERRY STEEL CUTTING KNIFE



47/62 ROKVEL STEEL STAINLESS SEMI CIRCLE
SUITABLE FOR COMPACT/UNITEC/CP BRAND
CHERRY PROCESSING MACHINES

CHERRY HAN ÇIĞE HOLDER FINGER

CHERRY STONE HOLDER FINGER
LONG-SHORT SET SUITABLE FOR
COMPACT/CP/UNITEC BRAND CHERRY
MACHINES.





11. YILDIRIM NISANLI & VE. DS. TİCARET. 114

OLIVE EXHAUST TUNNEL

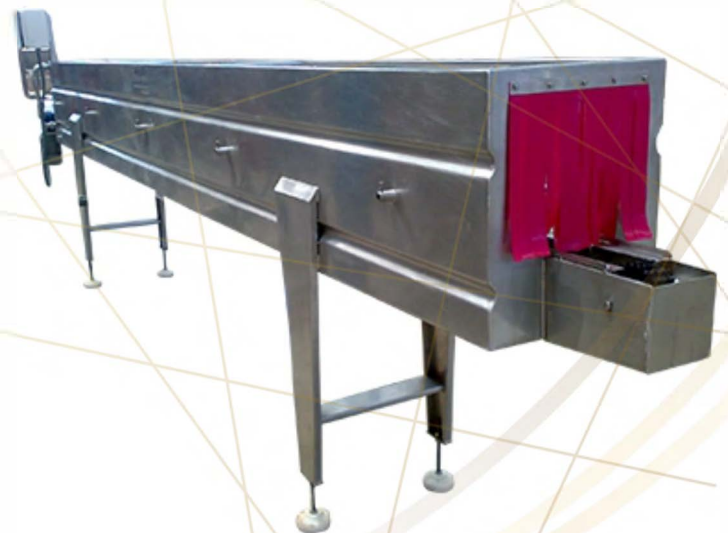
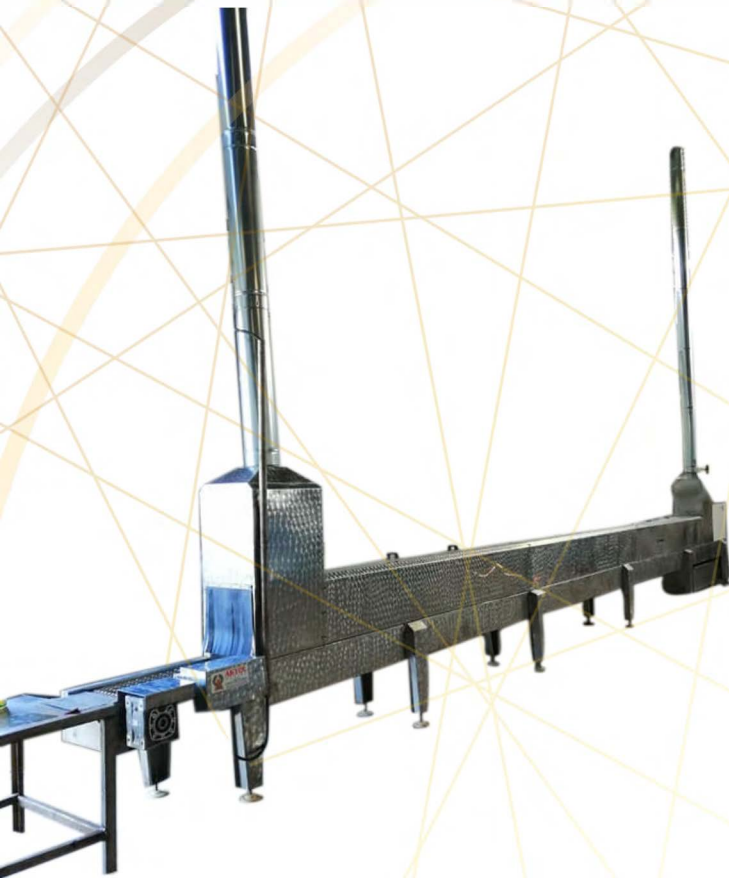



FRESH GRAPE AND CITRUS SELECTION AND PACKAGING LINE



JOB DESCRIPTION: CARRIES THE PRODUCTS ARRIVED IN CASES FROM THE GARDEN TO THE TABLES IN FRONT OF THE WORKERS - SELECTED PRODUCT - DISCARDED PRODUCT - EMPTY CASE - PROVIDES THE CARRYING SYSTEM

WIDTH: W1: 500 MM-W2: 2500 MM

LENGTH: 21000 MM

HEIGHT H1: 1750MM -H2: 2100MM

WEIGHT: 2000KG

AVERAGE POWER KW: 5 KW

REDUCER MOTOR 4 PIECES - STOP SAFETY - (RADIUS SYSTEM TORQUE INFLATOR SYSTEM)

INNER BODY: ST 37 STEEL ROLLER CONVEYOR LAYER 2 -ENDiess BELTS-4 PIECES

(DISMOUNTED SYSTEM) NUMBER OF TABLES 16 PIECES

EXTERNAL BODY: ST 37 STEEL CHASSIS TABLES FOLDABLE HANGER/ SCALE AREA CHROME

-AISI 304 / ENTRY-EXIT ROLLER CONVEYOR -(DISMOUNTED SYSTEM)

HOURS CAPACITY: VARIABLE DEPENDING ON THE PRODUCT/ 1-5 TONS AREA OF USE:

PACKAGING SELECTION - CITRUS

PRODUCT TYPES: FRESH GRAPE -APPLE - POMEGRANATE - ORANGE - PEAR - MANDARINE -

PLUMS - CITRUS PRODUCTS



APPLE PAINTING

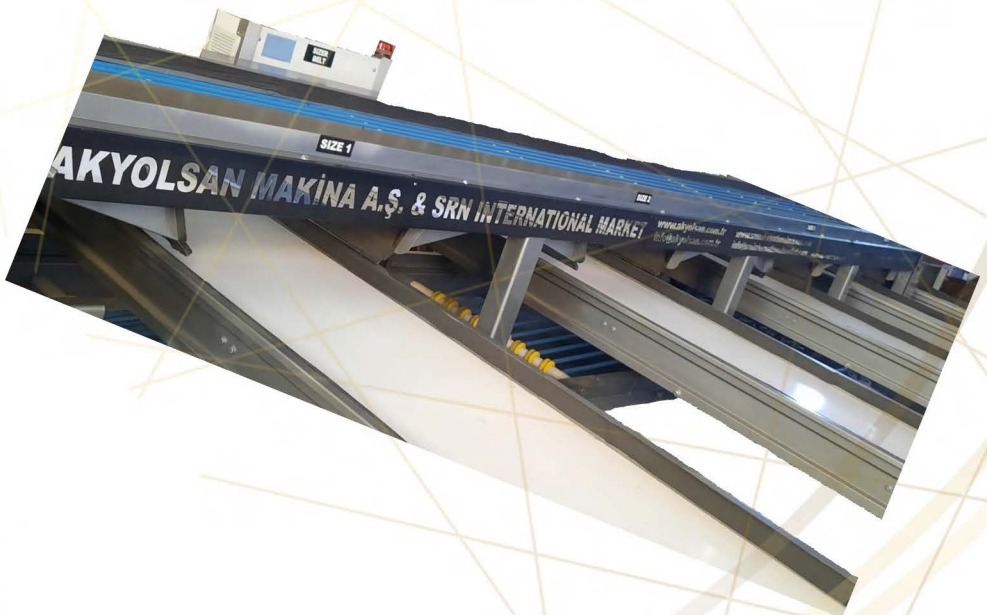



Polligranate Jacuzzi ,fashing

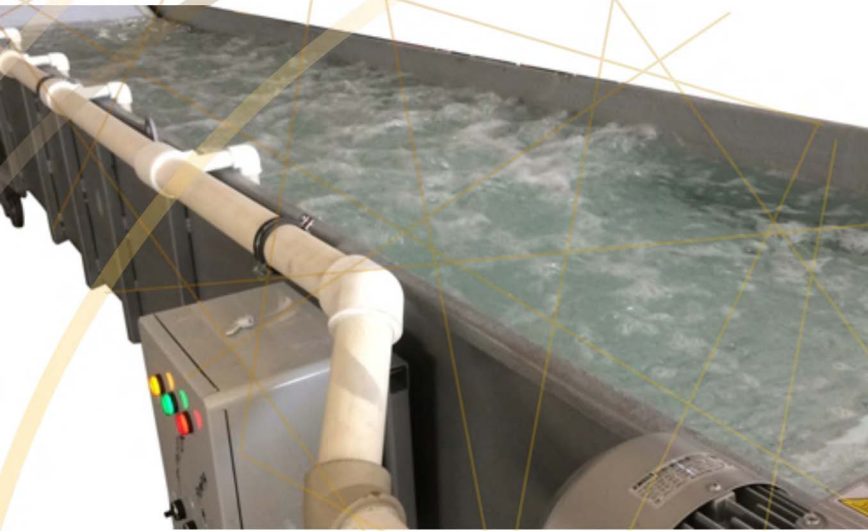



POMEGRANATE SEEDS MODULAR SELECTION PACKAGING LINE



JOB DESCRIPTION:

PROVIDES SELECTIVE VOLUMETRIC FILLING PACKAGING OF POMEGRANATE SEEDS AND SIMILAR PRODUCTS INSTALLATION AREA

DIMENSIONS: WIDTH: 7000 MM

LENGTH: 12000 MM/ CONVEYORS/ 5 PCS 300X600X800 MM/ 1 PC 250X8000 MM/ 1 PC 500X2000 MM/ 2 PCS 100X1000 MM/ 2 PCS 150X1500 MM

TECHNICAL DETAIL: 5 SELECTION CONVEYOR/ 1 PRODUCT COLLECTING CONVEYOR/ 1 SEPARATION CONVEYOR/ 2 FILLING CONVEYOR/ 2 PRODUCT APPLICATION TABLES

WEIGHT: 1500KG

AVERAGE POWER KW: MOTOR 9 PIECES - 5 KW - 380 WOLT - DK 10-35 / CONTROL PANEL

INNER BODY: MODULAR TAPE -AISI 304 CHROME

OUTER BODY: AISI 304 CHROME

CAPACITY HOUR: VARIABLE DEPENDING ON PRODUCT/ 0.20-0.75 TONS

AREA OF USE: MULTIPLE PRODUCT PROCESSING FACILITIES PRODUCT TYPES: POUCHED POMEGRANATES - LARGE-GRAINED PRODUCTS - CAPERS - CALIBRATED PRODUCTS - BOW-TINE PEPPER AND SIMILAR





JIRCULSON MAHINA X VE ISQ TICARET AS

QUALITY

RIGOR

DEVOTION



VACUUM CONTAINER



JOB DESCRIPTION:

IT ALLOWS DRIED FRUITS TO BE DISINFECTED BY CREATING A VACUUM

WIDTH: W1: 2400 MM-W2: 2800 MM

HEIGHT: H1: 2500 MM-H2: 2900 MM

LENGTH: D1: 4000 MM-D2: 5000 MM

WEIGHT: 8 TONS POWER: 24 M³ VOLUME -VACUUM PUMP 8 KW

INTERNAL BODY: ST37 STEEL 7 MMSHEET TIGHT SEAL GASKETED BEARING HINGE SYSTEM

EXTERNAL BODY: 200 NPI-200 NPU -60 0 SHAFT-1 M³ TANK ST 37 -MONOMETER-WITH ALARM SYSTEM -PANEL

CAPACITY HOUR: 22 M³

AREA OF USE: FOOD BUSINESS- CITRUS BUSINESSES PRODUCT TYPES: DRIED FRUITS - FIG -APRICOT - GRAPES -APPLE - PEAR

FUMLGATORY ROOM

JOB DESCRIPTION:

IT ALLOWS DRIED FRUITS TO BE DISINFECTED BY CREATING A VACUUM

EN: WI: 2400 MM -W2: 2800 MM

HEIGHT: H1: 2500 MM - H2: 2900 MM

LENGTH: D1: 4000 MM - D2: 5000 MM

WEIGHT: 8 TONS POWER: 24 M³ VOLUME-VACUUM PUMP 8 KW

INTERNAL BODY: ST37 STEEL 7 MM SHEET TIGHT SEAL GASKETED BEARING HINGE SYSTEM

EXTERNAL BODY: 200 NPI-200 NPU -60 0 SHAFT -1 M³ TANK ST 37 - MONOMETER -WITH ALARM SYSTEM - PANEL CLOCK CAPACITY: 22 M³

AREA OF USE: FOOD BUSINESS - CITRUS BUSINESSES

PRODUCT TYPES: DRIED FRUITS - FIGS -APRICOTS - GRAPES -APPLES - PEARS





Vibrating Fig Grading





COMPACT OLIVE GRADE WITH ELEVATOR

JOB DESCRIPTION:

PERFORMS CALIBRATION ACCORDING TO THE SIZE RANGE OF OLIVES AND SIMILAR PRODUCTS

DIMENSIONS: WIDTH W1: 600 MM-W2. 900MM

HEIGHT: H1.800 MM-H2.1200 MM

HEIGHT: D1. 4000 MM-D2.2000 MM-D3. 6000MM

TECHNICAL DETAIL: 10 MMPOLYURETHANE BELT/ 17 ROWS/ PRODUCT LOADING SYSTEM/ INFINITE TYPE BELT FAN SYSTEM

WEIGHT: 900KG

AVERAGE POWER KW: MOTOR 2 PIECES 15 KW -30 MIN SPEED DRIVE INVERTER 1 PIECE

INNER BODY: AISI 304 CHROME

OUTER BODY: ASI 304

CAPACITY PER HOUR: 1-5 TON

AREA OF USE: OLIVE BUSINESSES PRODUCT TYPES: OLIVES -CAPERS -PLUMS AND SIMILAR PRODUCTS

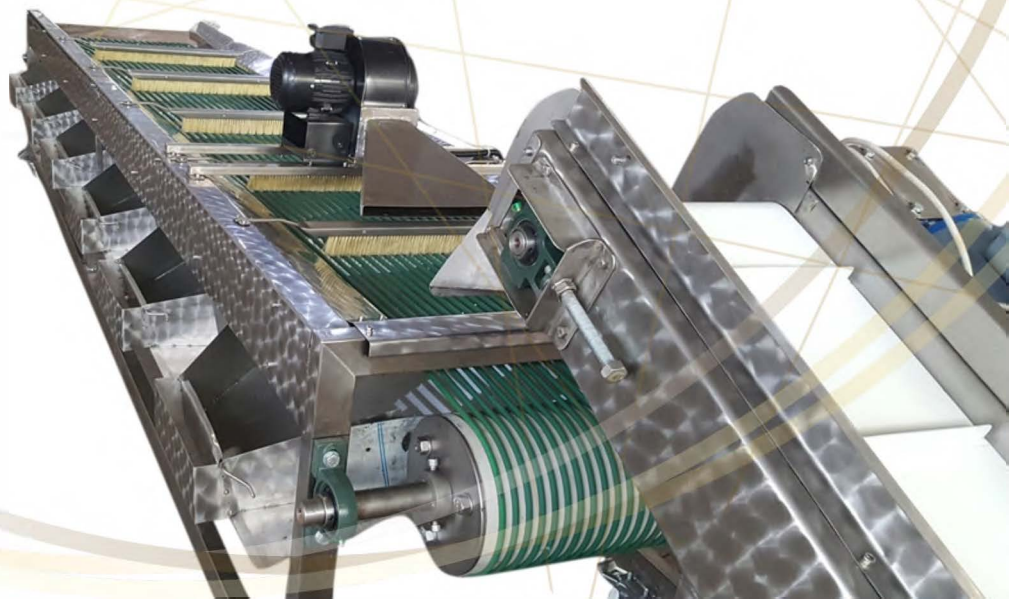

OLIVE CLASSIFICATION

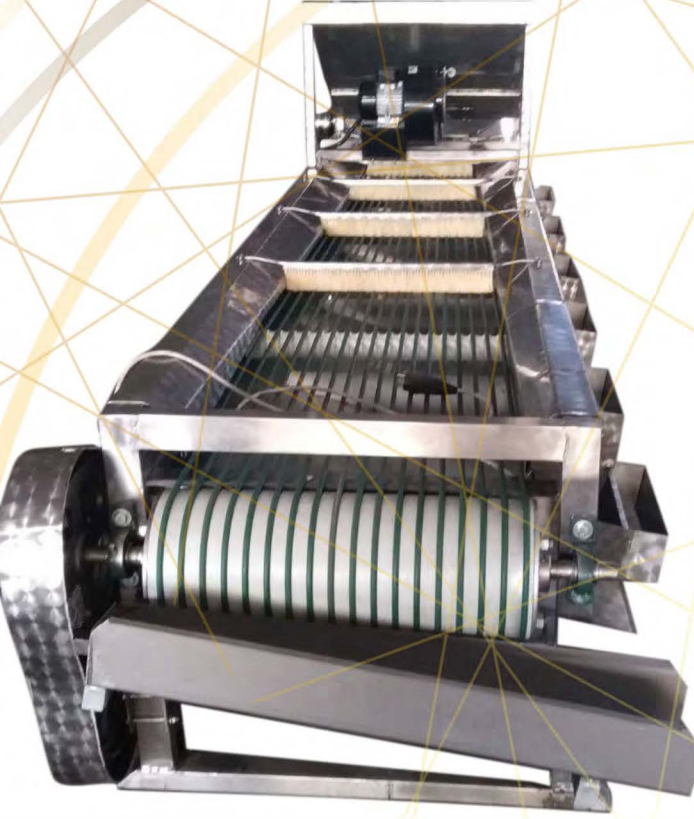

JOB DESCRIPTION:

PERFORMS CALIBRATION ACCORDING TO THE SIZE RANGE OF OLIVES AND SIMILAR PRODUCTS

DIMENSIONS: WIDTH W1: 600 MM-W2. 900MM

HEIGHT: H1.800 MM-H2.1200 MM

HEIGHT: D1. 4000MM -D2. 5000MM

TECHNICAL DETAIL: 10 MMPOLYURETHANE BELT/ 17 ROWS/ INFINITE TYPE BELT/ FAN SYSTEM/ TOP CHAMBER

WEIGHT: 800KG

AVERAGE POWER KW: MOTOR 2 PIECES 1.5 KW-30 MIN

INNER BODY: AISI 304 CHROME

EXTERNAL BODY: ASI 304 HOURS CAPACITY: 1-5 TONS

AREA OF USE: OLIVE BUSINESSES PRODUCT TYPES: OLIVES -CAPERS -PLUMS AND SIMILAR PRODUCTS



AKYOLSAN MAKINA & YEDE TICARET A.Ş.

ROTARY DRY PRODUCT WASHING



JOB DESCRIPTION:

IT PROVIDES PRE-WASHING BY ROTATING THE PRODUCTS ON ITS OWN AXIS - BY PROVIDING PRESSURIZED WATER - IT IS A MACHINE AUXILIARY EQUIPMENT.

WIDTH: W1: 600 MM-W2: 1250 MM

LENGTH: D1: 2000 MM-D2: 2500 MM

HEIGHT H1: 1250 MM-H2: 1500 MM

SYSTEM: WATER SUPPLY FROM THE MAINS -500 LT WATER BOILER

CIRCULATION PUMP -NOZZLE SPRAY SYSTEM SPEED DRIVE

WEIGHT: 400KG

AVERAGE POWER KW: 2 KW NUMBER OF MOTORS 2 PIECES+ CONTROL

PANEL INNER BODY: AISI 304 CHROME

OUTER BODY: AISI 304 CHROME

HOUR CAPACITY: VARIABLE DEPENDING ON PRODUCT/ 0.25 -1.25 -TON

AREA OF USE: FOOD BUSINESSES - CITRUS BUSINESSES/ PRODUCTS THAT REQUIRE PRE-WASHING WITH NATURAL WATER

PRODUCT TYPES: DRIED -APRICOTS -FIGS -RAPES -CHESTNUTS

JOB DESCRIPTION:

BY ROTATING THE PRODUCTS ON THEIR OWN AXIS - PRESSURIZED WATER

IT ENABLES PRE-WASHING BY GIVING

WIDTH: W1: 600 MM - W2: 1250 MM

LENGTH: D1: 1000 MM - D2: 2500 MM

HEIGHT: H1: 1250 MM - H2: 1500 MM

SYSTEM: WATER SUPPLY FROM THE MAINS- OUTLET CARRIER PALLET - NOZZLE

SPRAYING

SYSTEM

SPEED DRIVE WEIGHT: 200 KG

AVERAGE POWER KW: 2 KW NUMBER OF MOTORS 2 PIECES+ CONTROL PANEL

INNER BODY: AISI 304 CHROME

OUTER BODY: AISI 304 CHROME

HOUR CAPACITY: VARIABLE BY PRODUCT/ 0,25 1,25 - TON AREA OF USE:

FOOD BUSINESS - CITRUS BUSINESSES/ PRE-WASHING WITH NATURAL WATER

PRODUCTS YOU WANT

PRODUCT TYPES: DRIED -APRICOTS - FIGS - GRAPES - CHESTNUTS





DRIED FRUIT ROTARY CLASSIFICATION

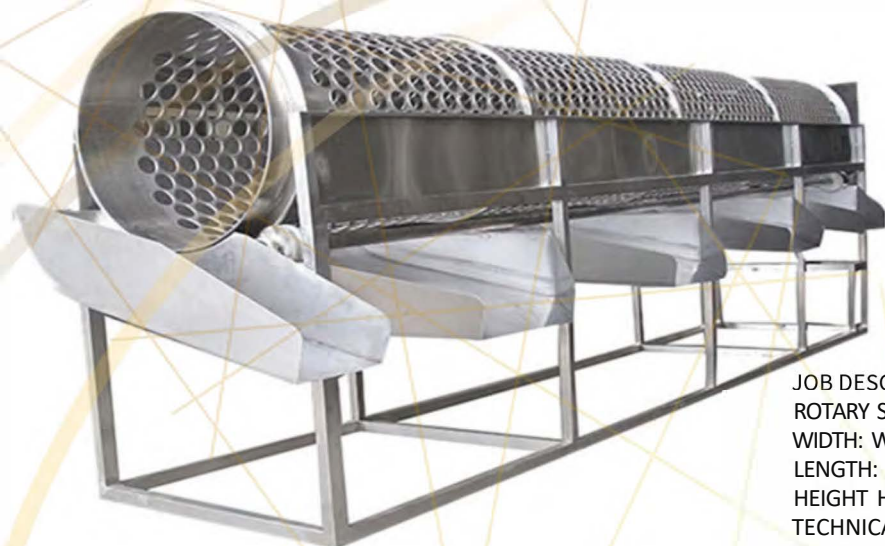

JOB DESCRIPTION:

ROTARY SYSTEM ENABLES UNIVERSAL CALIBRATION OF PRODUCTS TO BE DRAINED

WIDTH: W1: 900 MM-W2: 1500 MM

LENGTH: D1: 4500 MM-D2: 5500 MM

HEIGHT H1: 850 MM-H2: 2500 MM

TECHNICAL DETAIL: 1500

WEIGHT: 2500KG

AVERAGE POWER KW: 3 KW/ SPEED CONTROL INVERTER/ 380 WOLT / CONTROL PANEL

INNER BODY: AISI 304 CHROME

OUTER BODY: AISI 304 CHROME

HOURLY CAPACITY: 1-5 TONS VARIABLE DEPENDING ON THE PRODUCT AREA OF USE:

FOOD PROCESSING PACKAGING INDUSTRIES

PRODUCT TYPES: DRIED FIGS -APRICOTS - WALNUTS- CHESTNUTS-ALMONDS- AND SIMILAR PRODUCTS



JOB DESCRIPTION:

IT ALLOWS THE PRODUCTS TO BE CALIBRIZED BY ROTATING THEM ON THEIR OWN AXIS

WIDTH: W1: 600 MM-W2: 1200 MM

LENGTH: D1: 3000 MM-D2: 3500 MM

HEIGHT H1: 1250 MM-H2: 1500 MM

TECHNICAL DETAIL- PRODUCT FEEDING/ 3+1: 4 OUTLET EYE/ BOTTOM DRIVE SYSTEM/ DRILLING LENGTH DIAMETER ACCORDING TO THE DESIRED PRODUCT (STRAIGHT HOLE EYE SYSTEM)

WEIGHT: 350KG

AVERAGE POWER KW: 1.5 KW - SPEED DRIVE INVERTER

INTERIOR BODY: ST 37 STEEL CHROME PAINTED

EXTERNAL BODY: ST 37 STEEL CHROME PAINTED

CAPACITY PER HOUR: VARIABLE DEPENDING ON PRODUCT 0.25 -1 TONS

AREA OF USE: DRIED FRUIT PROCESSING FACILITIES/ CEREAL FACILITIES/ AGRICULTURE SECTOR

PRODUCT TYPES: DRIED AND DECED PRODUCTS -FIGS-RAPES-APRICOTS -LEUBLES AND SIMILARITIES-CHICKPEAS-LEUBLES -HAZELNUT -PEANTS



AKYOL SAN. MAH. NA. İVE. Dİ. TİCARET A.Ş.

YOU IMAGINE IT, WE BUILD IT





DRIED FRUIT CLASSIFICATION LINE

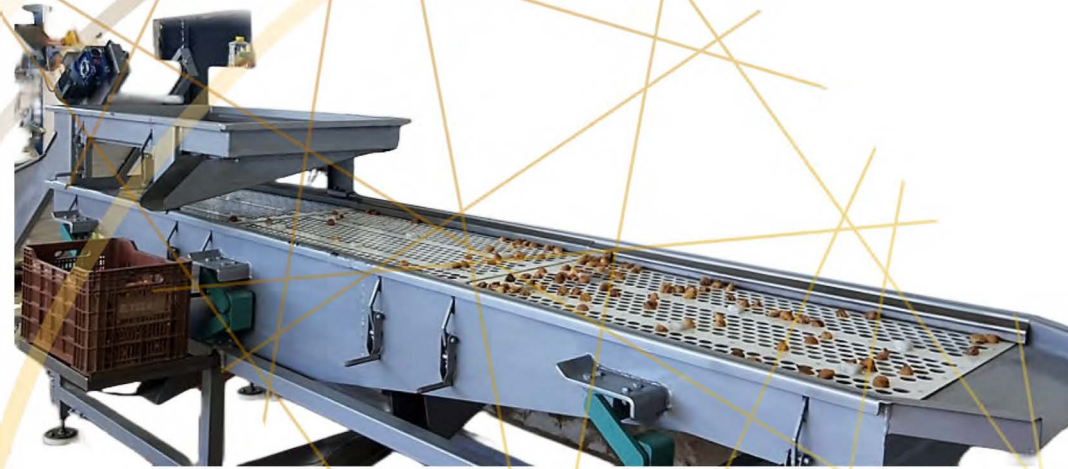

JOB DESCRIPTION:

DRIED FRUITS PROVIDE CALIBRATION WITH THE VIBRATION PROVIDED BY VIBRATION MOTORS

WIDTH: W1: 750 MM-W2: 1000 MM

LENGTH: D1: 3750 MM-D2: 5500 MM

HEIGHT: H1: 900 MM-H2: 1500 MMEQUIPMENT -LOADING CONVEYOR 1 PIECE/ SIEVE 1 PIECE

WEIGHT: 1000KG

AVERAGE POWER: 3 KW VIBRO MOTOR 2 PIECES - REDUCER 1 PIECE

INNER BODY: ST 37 STEEL-POLYETHYLENE

EXTERNAL BODY: ST 37 STEEL 4+15 EYE OUTLETS- ROSTA SWING ARM -ADJUSTABLE FEET ON ROUGH SURFACE

CAPACITY PER HOUR: VARIABLE DEPENDING ON THE PRODUCT 0.5 -2 TONS

AREA OF USE: DRIED FRUIT/ SUPPLIERS AND TRADERS

PRODUCT TYPES: DRIED APRICOTS -FIGS -RAPES -DIED PRODUCTS AND SIMILAR



IJYOVSAN MILCINA & VE DİS TICARET A.Ş.

Special Series Sieve

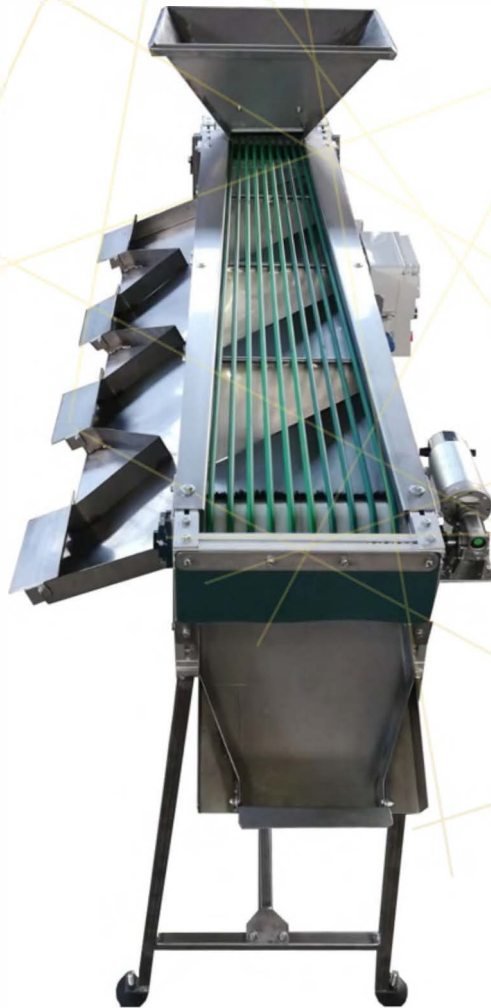



AKYOLSAN MAKINA & VE DIS TICARET A.S.

OLIVE CLASSIFICATION

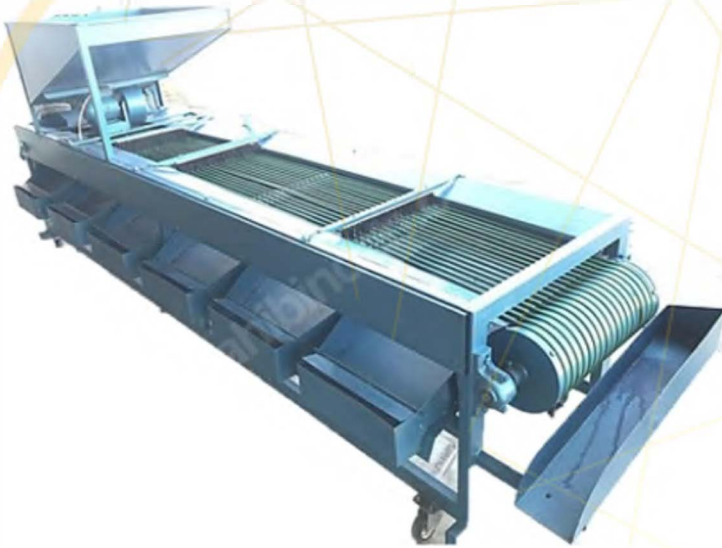

JOB DESCRIPTION:

PERFORMS CALIBRATION ACCORDING TO THE SIZE RANGE OF OLIVES AND SIMILAR PRODUCTS

DIMENSIONS: WIDTH W1: 600 MM -W2. 900MM

HEIGHT: H1 .800 MM -H2.1200 MM

HEIGHT: D1. 3000MM -D2. 4000MM

TECHNICAL DETAIL: 10 MM POLYURETHANE BELT/ 17 ROWS/ INFINITE TYPE BELT/ FAN SYSTEM/ TOP CHAMBER

WEIGHT: 650KG

AVERAGE POWER KW: MOTOR 2 PIECES 1.5 KW -30 MIN

INTERIOR BODY: ST 37 STEEL CHROME BLUE PAINTED

EXTERNAL BODY: ST 37 STEEL BLUE PAINTED

CAPACITY PER HOUR: 1-5 TON

AREA OF USE: OLIVE BUSINESSES

PRODUCT TYPES: OLIVES -CAPERS -PLUMS AND SIMILAR PRODUCTS



JAYALAKSHI MATHA, 3 RD FLOOR, TIRUPUR 69

Fig Jacuzzi Washing

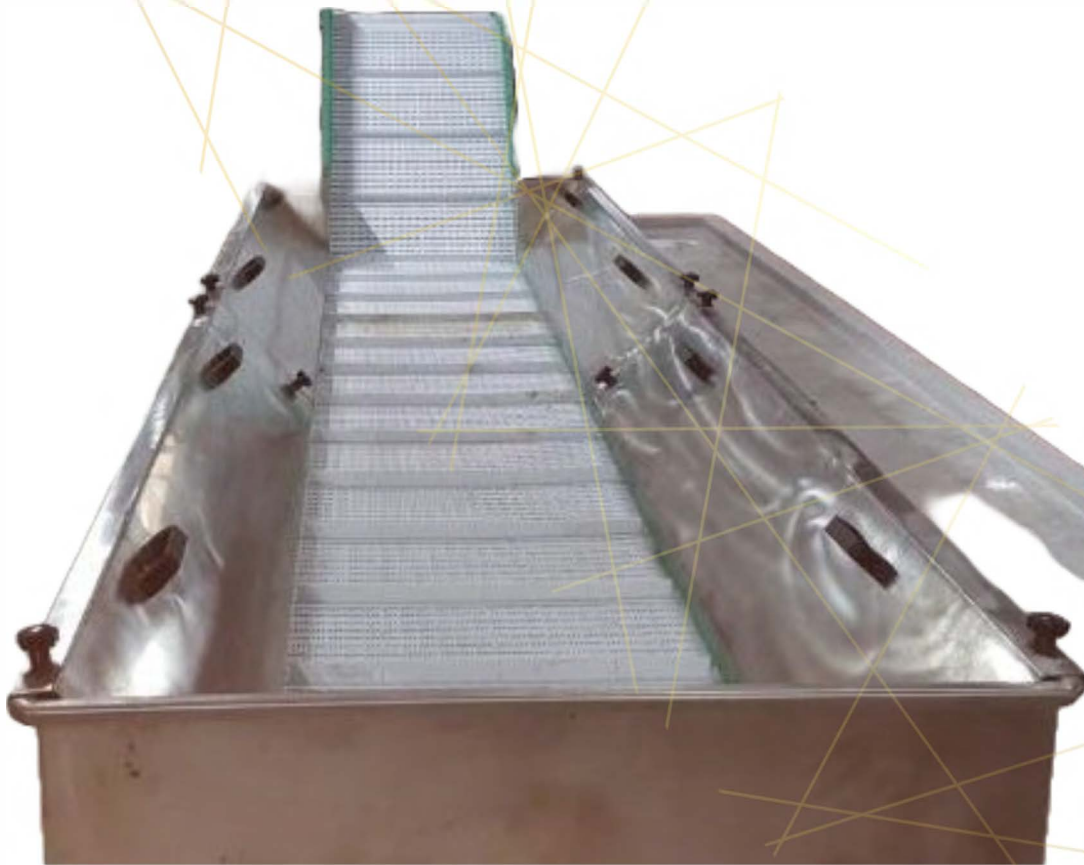



AKYOL SAN MAKINA VE DIJİTAL TİCARET A.Ş.

Olive Brine Filling Line

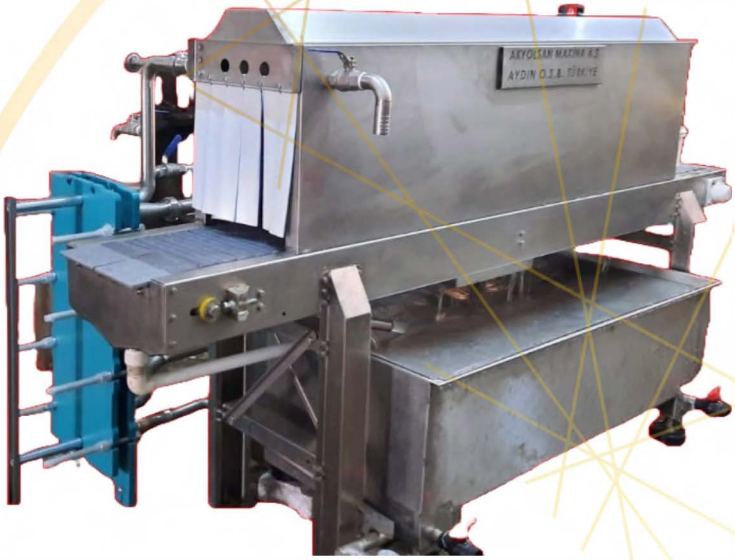



ARVALAN MAKINA Ç. VE Dİ. TİCARİET A.Ş.

Olive Elevator





İKYO SAN MARINA & VE DİŞ. TİCARET A.Ş.

YEARS OF EXPERIENCE



**Östun
Kalite**



**Gözüm
Odak
İ Anlay101**



**Uzman
Kadro**



360 DEGREE CHROME MODULAR CONVEYOR



JOB DESCRIPTION:

IT SERVES AS AUXILIARY EQUIPMENT IN SELECTION AND SEPARATION OF PRODUCTS - IN COMPACT LINE INSTALLATIONS AND PRODUCT TRANSFERS

DIMENSIONS INSTALLATION AREA: 3.5 M X 3 M

EN: W1. 600MM -W2.3000MM -W3.1400MM

SIZE D1. 3500MM -D2. 2300MM

HEIGHT H1: 800 MM

TECHNICAL DETAIL: MODULAR ROTATION SYSTEM - DOUBLE TORQUE SYSTEM - ADJUSTABLE FOOT SYSTEM - PERIMETER LENGTH 12 M.

WEIGHT: 500KG

AVERAGE POWER KW: MOTOR 2 PIECES 1.5 KW 30 MIN - SPEED DRIVE INVERTER

INNER BODY: AISI 304 CHROME

OUTER BODY: AISI 304 CHROME

HOURLY CAPACITY: VARIABLE DEPENDING ON PRODUCT

AREA OF USE: FOOD PRODUCTION FACILITIES - PACKAGING FACILITIES

PRODUCT TYPES: CITRUS INDUSTRY - DRIED FRUITS INDUSTRY - PACKAGING INDUSTRY



İSTANBUL MUHURİCE VE İSTİCARET İLİ

TIN TIPPING

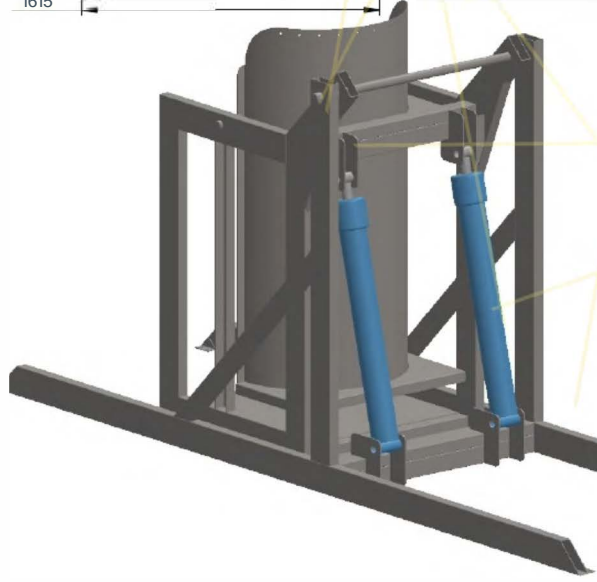
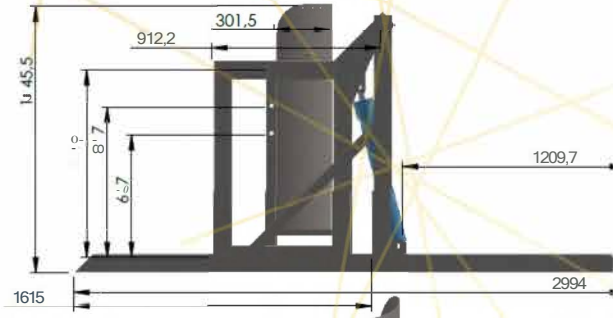

60 LU	Ko olirnu	Gi Ji' Esallı	Ghanu1	2.000Gr.	3900-	:ISOc	MQ	8.2?G.10x11/1	
12-011	ffE1lhal	YYP	0 mm	08	3.700Gr.	1200-	,000,	3MQ	7>h500K85
15-01T	ME	PEPetbn	10 mm.	0.8Jmm.	5.100Gr.	8200-	,000,	,C,	Wx.95x95
2211T	WPE lth i	YPE PdNm	11 mm	0.80 n m	7.000Gr	1.250Gr.	6106<	100Gr.	1000x591x18

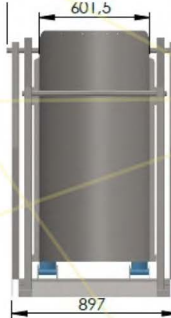

**İPLASTİK VARİL DEVİRME
220LT- 150LT-120LT- 60 LT
LİFT HİDROLİK DEVİRME SİSTEMİ
ÇİFT POMPALI
MOTOR GÜCÜ 2,2 KW
STROK 700 MM
JOİSTİK KONTROL SİSTEMİ
KUMANDA KONTROL PONO UNİTE
MAKİNA BRUT 320 KG
KALDIRMA KAPASİTE 500 KG
AISI 304 KROM GOVDE**

TS 1909 e göre DIN 7198 e göre Diğer Toleranslar		Toleranslar: DIN ISO 2768	Şİ/1	PANJAKÇU	DEVİRME MONTAJ 3
0,5-3	±0,05	±0,05	±0,05	±0,05	±0,05
3-6	±0,05	±0,05	±0,05	±0,05	±0,05
6-30	±0,1	±0,1	±0,1	±0,1	±0,1
30-100	±0,15	±0,15	±0,15	±0,15	±0,15
100-200	±0,2	±0,2	±0,2	±0,2	±0,2
200-400	±0,25	±0,25	±0,25	±0,25	±0,25
400-1000	±0,3	±0,3	±0,3	±0,3	±0,3
1000-2000	±0,4	±0,4	±0,4	±0,4	±0,4

ÇİZEN	HUJINGO	DEVİRME MONTAJ 3
KONTROL	PANJAKÇU	
TARİH:	A4	
MALZEME	SEPAŞI Ölçüsü:	
MAKİNA		

MÜŞTERİ ADI: ...

ÖLÇEK: 1:50

OPERASYON



AKYOLUNMAKINA-VEB-TICARET A.Ş.

MULTIPURPOSE MODULAR SELECTION TAPE

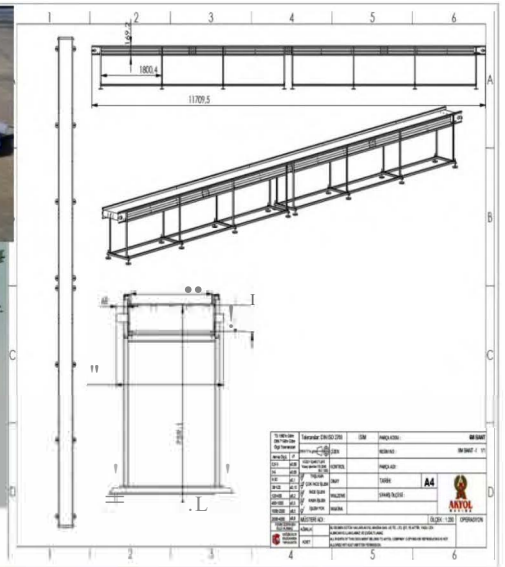

JOB DESCRIPTION:

IT SERVES AS AUXILIARY EQUIPMENT IN SELECTION AND SEPARATION OF PRODUCTS - IN COMPACT LINE INSTALLATIONS

WIDTH: W1 :700 MM -W2: 800 MM

LENGTH: D1: 3000 MM

HEIGHT H1: 800 MM

WEIGHT: 150KG

AVERAGE POWER KW: 1.5 KW 30 MIN

INNER BODY: ASIS 304 CHROME MODULAR TAPE

EXTERNAL BODY: ASIS 304 CHROME

HOURS CAPACITY: VARIABLE DEPENDING ON THE PRODUCT AREA OF USE: FOOD BUSINESSES - PACKAGING FACILITIES - PRODUCTION AREAS

PRODUCT TYPES: LIGHT PACKAGED PRODUCTS - FRUITS - VEGETABLES - PLACES THAT REQUIRE FILLING - LEGUMS - DRIED PRODUCTS AND SIMILAR



MULTI-PURPOSE SELECTION TAPE

JOB DESCRIPTION:

IT SERVES AS AUXILIARY EQUIPMENT IN SELECTION AND SEPARATION OF PRODUCTS - IN COMPACT LINE INSTALLATIONS

WIDTH: W1 :700 MM -W2: 800 MM

LENGTH: D1: 3000 MM

HEIGHT H1: 800 MM

WEIGHT: 150KG

AVERAGE POWER KW: 1.5 KW 30 MIN

INNER BODY: ST37 STEEL CHROME PAINTED PVS TAPE

EXTERNAL BODY: ST37 STEEL CHROME PAINTED

HOOR CAPACITY: VARIABLE DEPENDING ON PRODUCT

AREA OF USE: FOOD BUSINESSES - PACKAGING FACILITIES - PRODUCTION AREAS

PRODUCT TYPES: LIGHT PACKAGED PRODUCTS - FRUITS - VEGETABLES - PLACES THAT REQUIRE FILLING - LEGUMS - DRIED PRODUCTS AND SIMILAR



SELECTION CONVEYOR WITH ELEVATOR



JOB DESCRIPTION:

COMPACT SYSTEM SELECTION SEPARATION CONVEYOR - SERVES AS COMPLEMENTARY EQUIPMENT IN COMPACT LINE INSTALLATIONS

DIMENSIONS: SELECT EN-W1 :800 MM -W2: 850 MM ELEVATOR

WIDTH: 200 MM -LENGTH-D1: 800 MM -D2:1500 MM -D3: 6000 MM

TECHNICAL DETAIL: COMPACT SELECTION CONVEYOR - LIGHTING - CONTROL PANEL - ELEVATOR - DISCARD WASTE SECTION

WEIGHT: 450KG

AVERAGE POWER KW: 1.5 KW NUMBER OF MOTORS 2 PIECES - SPEED DRIVE INVERTER 1 PIECE

INNER BODY: ST37 STEEL CHROME PAINTED PVS TAPE

EXTERNAL BODY: ST37 STEEL CHROME PAINTED

CAPACITY PER HOOR: VARIABLE DEPENDING ON PRODUCT 0.25-1 TONS

AREA OF USE: DRIED FRUIT FOOD BUSINESS - PACKAGING FACILITIES - PRODUCTION AREAS

PRODUCT TYPES: DRIED AND DECED -FRUIT -FIGS APRICOTS -OLIVES AND SIMILAR -Coarse grained products that need to be selected



SELECTION LINE WITH TWIN LOADING CONVEYOR

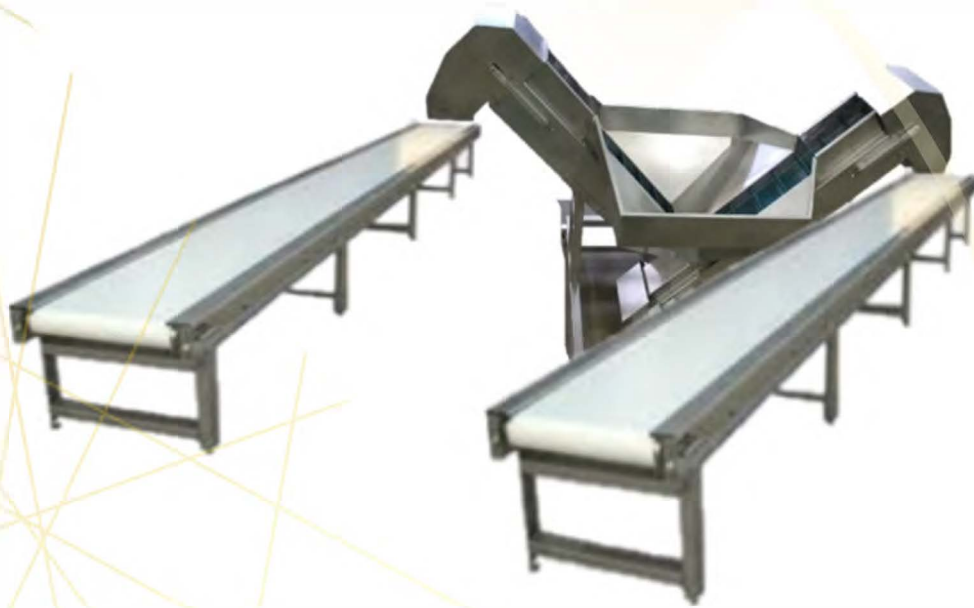

JOB DESCRIPTION:

IT SERVES AS AUXILIARY EQUIPMENT IN SELECTION AND SEPARATION OF PRODUCTS - IN COMPACT LINE INSTALLATIONS

DIMENSIONS: SELECT EN-W1 :700 MM -W2: 800 MM

SIZE-D1: 5000 MM

HEIGHT: H1: 800MM

ELEVATOR WIDTH: W1: 250 MM W2: 1000X750

LENGTH: D1: 2000 MM

HEIGHT: H1: 300 MM - H2: 1250 MM

TECHNICAL DETAIL: SINGLE BUNKER DOUBLE OUTLET ELEVATOR - FEEDING 2 TAPE AT THE SAME TIME

WEIGHT: 750KG

AVERAGE POWER KW: 2.5 KW - 30 MIN 3 MOTORS - SPEED DRIVE INVERTER 1 PIECE

INNER BODY: ASIS 304 CHROME PVS TAPE

EXTERNAL BODY: ASIS 304 CHROME

HOURLY CAPACITY: VARIABLE DEPENDING ON PRODUCT 0.50 - 3 TONS

AREA OF USE: FOOD BUSINESSES - PACKAGING FACILITIES PRODUCTION AREAS

PRODUCT TYPES: DRIED AND DECED - FRUITS - FIGS, APRICOTS AND SIMILAR - LARGE-GRAINED

PRODUCTS TO CHOOSE



PT. KARYASAN MILIKHA & VE DES TICABET AS

HT 50 - {L} TYPE CHROME MODULAR CONVEYOR

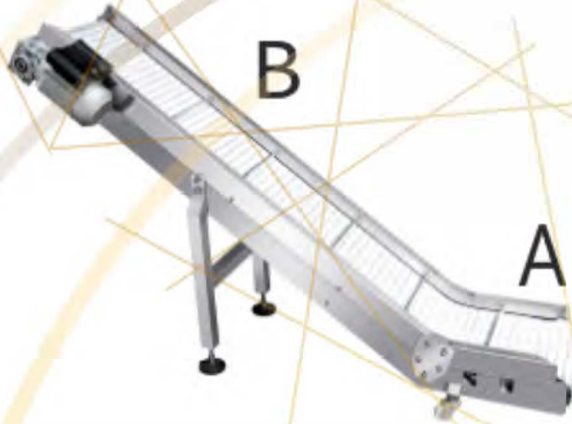

JOB DESCRIPTION:

USED AS PRODUCT LOADING AND AUXILIARY EQUIPMENT

DIMENSIONS: EN-W1 .550 MM -W2.380 MM -W3. 350MM

LENGTH.3000 A.400 / H.2420 MM

TECHNICAL DETAIL: WING CARRIER MODULAR -HT50 SERIES INTERMEDIATE DISTANCE 250 MM -H40 MM -PU1000 FRICTION SLIDE

WEIGHT: 200KG

AVERAGE POWER KW: 0.55 KW -MOTOR 1 PIECE -30 MIN

INNER BODY: ASISI 304 CHROME

EXTERNAL BODY: ASASI 304 CHROME

HOOR CAPACITY: VARIABLE DEPENDING ON PRODUCT TYPE

AREA OF USE: PACKAGING FACILITIES - CITRUS FACILITIES - DRIED FRUIT PROCESSING FACILITIES

PRODUCT TYPES: COARSE-GRAINED PRODUCTS

EXAMPLE: FIG-OLIVES-PLUMS-DIED PRODUCT-SEEDS-LEGUMS

HT 50 - (Z)TYPE MODULAR CHROME CONVEYOR

JOB DESCRIPTION:

USED AS PRODUCT LOADING AND AUXILIARY EQUIPMENT

DIMENSIONS: EN-W1 .500 MM -W2.380 MM -W3. 350MM

SIZE-B.3000-A.400 I H. 2420 MM

TECHNICAL DETAIL: WING CARRIER MODULAR-HT 50 SERIES INTERMEDIATE DISTANCE 250 MM -H 40 MM -PU1000 FRICTION SLIDE -COLOR WHITE

WEIGHT: 180KG

AVERAGE POWER KW: 0.55 KW -MOTOR 1 PIECE -30 MIN

INNER BODY: ASISI 304 CHROME

EXTERNAL BODY: ASASI 304 CHROME

HOOR CAPACITY: VARIABLE DEPENDING ON PRODUCT TYPE

AREA OF USE: PACKAGING FACILITIES - CITRUS FACILITIES - DRIED FRUIT PROCESSING FACILITIES

PRODUCT TYPES: COARSE-GRAINED PRODUCTS EXAMPLE: FIG-OLIVES-PLUMS-DIED PRODUCT-SEEDS-LEGUMS



HT 50 - RIGHT ANGLE MODULAR CHROME CONVEYOR

JOB DESCRIPTION:

USED AS PRODUCT LOADING AND AUXILIARY EQUIPMENT

DIMENSIONS: EN-W1. 650MM/W2. 500MM/W3. 450MM

SIZE-5250 MM

HEIGHT D.4000 MM -H .4650 MM

TECHNICAL DETAIL: WING CARRIER MODULAR -HT 50 SERIES INTERMEDIATE DISTANCE

250 MM -H 50 MM -PU1000 MM FRICTION SLIDE -COLOR WHITE

WEIGHT: 240KG

AVERAGE POWER KW: 11 KW -MOTOR 1 PIECE -30 MIN

INNER BODY: ASISI 304 CHROME

EXTERNAL BODY: ASASI 304 CHROME

HOOR CAPACITY: VARIABLE DEPENDING ON PRODUCT TYPE

AREA OF USE: PACKAGING FACILITIES - CITRUS FACILITIES - DRIED FRUIT PROCESSING FACILITIES

PRODUCT TYPES: COARSE-GRAINED PRODUCTS EXAMPLE: FIG-OLIVES-PLUMS-DIED

PRODUCT-SEEDS-LEGUMS

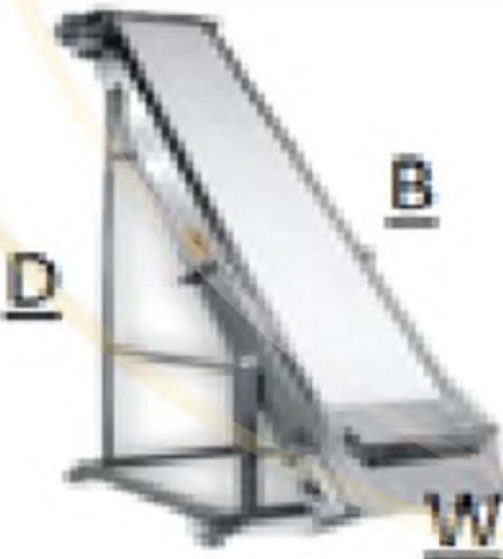



AKYORSAN MAKINA VE DIS TICARET A.S.

HT SO-MODULAR CHROME (2) CONVEYOR WITH PRE-WASHING



JOB DESCRIPTION:

BY PROVIDING A SOFT FALL, THE PRODUCT ACTIVITIES AS AN AUXILIARY MACHINE FOR PRE-WASHING, RINING AND INTER-MACHINE TRANSFER OF SENSITIVE FRUITS.

DIMENSIONS: B-1000-600-600/A1450-500/C 4000/W1 .800-700-650/D 500/H .3200-2900/L.4300 MM

TECHNICAL DETAIL: HT 50 SERIES BAND-WING INTERMEDIATE DISTANCE 250 H40 MM -500X500X1400
INLET BOILER -WATER VOLUME MAX 200 LT -1 PIECE DRAIN 1" -3/4 INLET 2 PIECES -INCLINE ANGLE 45°

WEIGHT: 450KG

AVERAGE POWER KW: 1.5 KW -30 MIN

INNER BODY: AISI 304 CHROME

OUTER BODY: AISI 304 CHROME

CAPACITY PER HOUR: VARIABLE DEPENDING ON PRODUCT TYPE 0.25 -2.5 TONS

AREA OF USE: PACKAGING FACILITIES - CITRUS FACILITIES - DRIED FRUIT PROCESSING FACILITIES

PRODUCT TYPES: CHERRY - PLUM - OLIVE - FIG - CHESTNUT - APPLE - PEAR - DRIED GRAPES - DRIED FIG - APRICOT AND SIMILAR



CONVEYORS

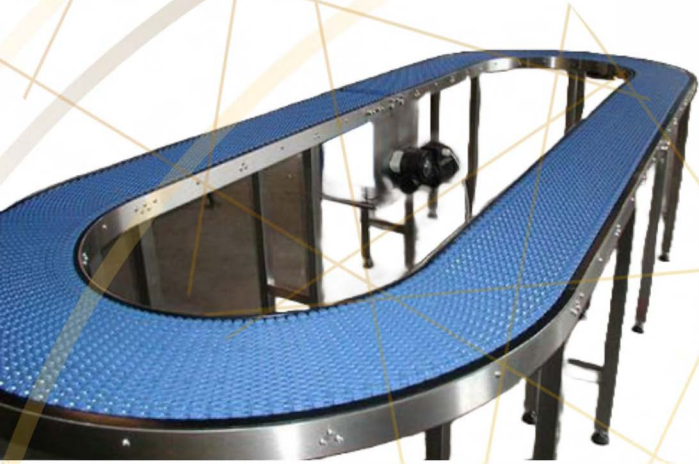

Modular Conveyor

"U" Type Modular Conveyor



Modular Conveyor



AKYOR SAN MARMARA SİYER DİŞ TİCARET A.Ş.

SELECTION BAND



JOB DESCRIPTION:

PERFORMING THE SELECTION PROCESS FOR THE PRODUCTS POURED FROM THE RESERVOIR TO THE BELT.

CODE-A-S26 INOX -XWM6 /130-SELECTION TAPE

WIDTH: W1: 700 MM

LENGTH: D1: 6000 MM

HEIGHT: H1: 750 MM

POWER/KW+ SYSTEM: 0.37 KW 2 PIECES/ SPEED DRIVE/ REDUCER DK 28 - DK 25 / TOTAL POWER - 1 KW

INNER BODY SYSTEM: SUB-CHASSIS ST37 INOX PAINT - LIGHTING/ CAST STEEL BEARING/

SELECTING POLYURETHANE TAPE

OUTER BODY: AISI 304 CHROME

HOURS CAPACITY: VARIABLE FROM 200 KG TO 1500 KG

FUEL TYPE: ELECTRIC

PRODUCT TYPES: HAZELNUT/ HALNUT / HALNUT / PEANUT HALL/ PEANUT IN SHELL/ LEBLEBI / ALMOND /WALNUT/

FIG/ OLIVE/ CASHJU / DRIED APRICOT/ DRIED FIG/ WALNUT



ANCOBAN MARINA (C.A.)

THE ONLY ADDRESS OF UNCHANGING QUALITY WITH 22 YEARS OF EXPERIENCE



We are a leader in the sector by constantly improving technological innovations, employee qualifications and our relations with all local and foreign customers.



UL. KRAJEVICI 4 VUKOVARSKA AG

LABORATORY-MICRO BUSINESS TYPE RIGHT ANGLE CHROME SCREW CONVEYOR

JOB DESCRIPTION:

TRANSPORTING SHREDDED PRODUCTS DIVIDED INTO PARTICLES ACCORDING TO THE SCREW RATIO AND IT ASSUMES THE DUTY OF AUXILIARY EQUIPMENT IN TRANSFERS

DIMENSIONS: W.D. 750X750/ HI. 2300 -H2.2000 / BUNKER 250X250/ CHASSIS 750X750 MM

TECHNICAL DETAIL: LOWER TABLE/ ROTARY LOCK WHEEL/ ANGLE

90 DEGREE/ ES 40 ENGINE/ 50X22X4 HT SCREW/ SIDE OUTLET PIPE-72X2X 100X2000 MM/ POLYURETHANE BEARING WEIGHT: 55KG

AVERAGE POWER KW: 0.55 KW 40 MIN

INNER BODY: AISI 304 CHROME

OUTER BODY: AISI 304 CHROME

CAPACITY PER HOUR: VARIABLE DEPENDING ON PRODUCT TYPE: 10-350 KG

AREA OF USE: LABORATORIES-MINIATURE DEMO BUSINESSES

PRODUCT TYPES: WHEAT - WOOD

POWDER - SOFT Shavings AND DERIVATIVES - CORE



LABORATORY AND MICRO BUSINESS TYPE HORIZONTAL ANGLE CHROME SCREW CONVEYOR (ENDLESS TYPE REDUCER)



JOB DESCRIPTION:

IT SERVES THE DUTY OF AUXILIARY EQUIPMENT IN CARRYING AND TRANSFERING SHREDDED PRODUCTS, WHICH ARE SEPARATED INTO PARTICLES ACCORDING TO THE SCREW RATIO.

DIMENSIONS: LENGTH: 2000-2300MM

TECHNICAL DETAIL: ES 40 ENGINE/ 50X22X4 HT SCREW/ SIDE OUTLET PIPE 72X2X100X2000 MM/ POLYURETHANE BEARING

WEIGHT: 45KG

AVERAGE POWER KW: 0.55 KW 40 MIN

INNER BODY: AISI 304 CHROME

OUTER BODY: AISI 304 CHROME

CAPACITY PER HOUR: VARIABLE DEPENDING ON PRODUCT TYPE: 10-350 KG

AREA OF USE: LABORATORIES - MINIATURE DEMO BUSINESSES

PRODUCT TYPES: WHEAT -WOOD POWDER -SOFT Shavings AND DERIVATIVES -CORE



MICRO-LABORATORY TYPE HORIZONTAL ANGLE CHROME SCREW CONVEYOR

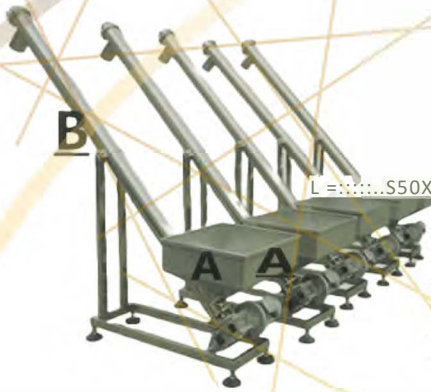

JOB DESCRIPTION:

IT ACTIVITIES AS AUXILIARY EQUIPMENT IN CARRYING AND TRANSFERING SHREDDED PRODUCTS, WHICH ARE SEPARATED INTO PARTICLES ACCORDING TO THE SCREW RATIO.

DIMENSIONS: L 3000 / H1.3500 H2. 3000 / BUNKER 500X500 / CHASSIS 1000X2000 MM

TECHNICAL DETAIL: BOTTOM TABLE/ ANGLE 50 DEGREES/ES 75 MOTOR/ 148X48X4 HT SPIRAL/ SIDE OUTLET PIPE-165X2X

L =S50X4000 MM/ POLYURETHANE BEARING

WEIGHT: 200KG

AVERAGE POWER KW: 1.1 KW 40 MIN

INNER BODY: AISI 304 CHROME

OUTER BODY: AISI 304 CHROME

CAPACITY PER HOUR: VARIABLE DEPENDING ON PRODUCT TYPE: 10-1000 KG

AREA OF USE: PACKAGING -FOOD CITRUS-DRIED FRUIT -CONSTRUCTION

PRODUCT TYPES: WHEAT -WOOD POWDER -SOFT Shavings AND DERIVATIVES -CORE

MICRO-LABORATORY TYPE U HORIZONTAL ANGLE CHROME SCREW CONVEYOR (REDUCER TYPE WORM)



JOB DESCRIPTION:

IT ACTIVITIES AS AUXILIARY EQUIPMENT IN CARRYING AND TRANSFERING SHREDDED PRODUCTS, WHICH ARE SEPARATED INTO PARTICLES ACCORDING TO THE SCREW RATIO.

DIMENSIONS: LENGTH 1500-1700 MM

TECHNICAL DETAIL: ES 30 ENGINE/ 65X27X4 HT SCREW/ SIDE OUTLET PIPE 72X2X100X1500 MM/

POLYURETHANE BEARING

WEIGHT: 40KG

AVERAGE POWER KW: 0.37 KW 40 MIN

INNER BODY: AISI 304 CHROME

OUTER BODY: AISI 304 CHROME

CAPACITY PER HOUR: VARIABLE DEPENDING ON PRODUCT TYPE: 10-150 KG

AREA OF USE: LABORATORIES -MINIATURE DEMO BUSINESSES PRODUCT TYPES: WHEAT -WOOD POWDER -SOFT

Shavings AND DERIVATIVES -CORE



MULTI-PURPOSE SELECTION AND TRANSFER TAPE



JOB DESCRIPTION: TRANSFER OF PRODUCTS- SELECTION OF PRODUCTS WITH LIGHT MASS WEIGHT
WIDTH: W1: 500 MM-W2: 800 MM
SIZE D1: 2000 MM-D2: 2250 MM
HEIGHT H1: 650 MM-H2: 800 MM BOTTOM TABLE: 1000X500 MMWEIGHT: 100 KG
AVERAGE POWER KW: 0.55 30 MIN
INNER BODY: ST37 STEEL CHROME PAINTED -PVS TAPE
EXTERNAL BODY: ST37 STEEL CHROME PAINTED
CAPACITY PER HOUR: 0.20-0.75 TONS VARIABLE DEPENDING ON THE PRODUCT
AREA OF USE: FOOD BUSINESSES - PACKAGING FACILITIES- PRODUCTION AREAS
PRODUCT TYPES: LIGHT PACKAGED PRODUCTS - FRUITS - VEGETABLES- PLACES THAT REQUIRE FILLING - LEGUMS- DRIED PRODUCTS AND SIMILAR

PVC BELT ANGLE ADJUSTABLE CHROME LOADING CONVEYOR

JOB DESCRIPTION:

IN PLACES WHERE HEIGHT ADJUSTMENT IS REQUIRED, ANGLE ADJUSTMENT IS MADE AND THE PRODUCT FALLS TO THE DESIRED POINT. IT IS USED AS AUXILIARY MACHINE EQUIPMENT.

DIMENSIONS: B:600 A:600/C 3500/H1.3300 H2. 2900/W 200-150/L 2400MM

TECHNICAL DETAIL: 2 MM BODY -BUNKER BOILER-ANGLE ADJUSTMENT SCREW-WHEEL WITH ROTARY LOCK-WINGED PVS TAPE T25 -BOTTOM WITH HINGE SYSTEM

WEIGHT: 220KG

AVERAGE POWER KW: 1.1 KW -30 MIN

INNER BODY: AISI 304 CHROME

OUTER BODY: AISI 304 CHROME

CAPACITY PER HOUR: VARIABLE DEPENDING ON THE PRODUCT 0.25 -1.5 TONS

AREA OF USE: PACKAGING FACILITIES- CITRUS FACILITIES - DRIED FRUIT PROCESSING FACILITIES

PRODUCT TYPES: CHERRY - PLUM - OLIVE- FIG - CHESTNUT -APPLE- PEAR- DRIED GRAPE- DRIED FIG -APRICOT AND SIMILAR

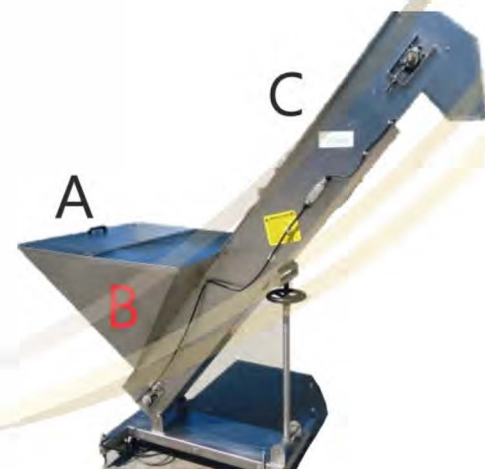



AKYOLSAN MAKINA & VE DIS TI CARET A.S.

Angled Roller Conveyor

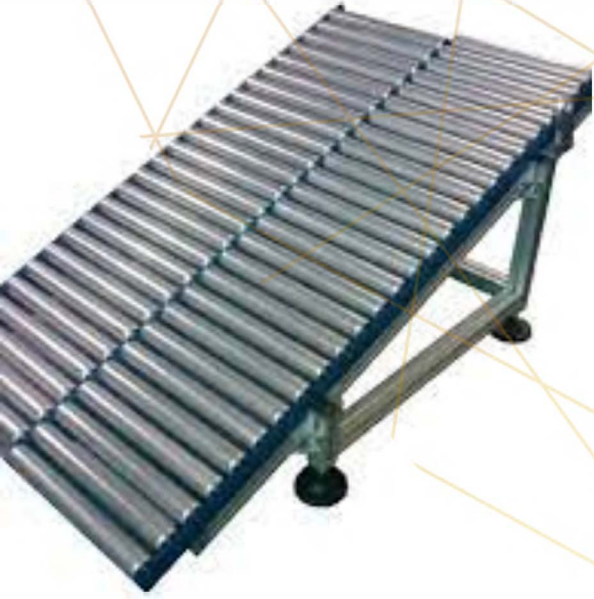

Power Type Conveyor



Folding Type Conveyor





PT. ARYOL MILIKSI & DI SUCI, LTD. A.

BOX CARRYING TROLLEY



REVISI	Toleransi: DIN ISO 2768	ISIRI	PANCA KODU :	KT-MONTAJ 4
Desain				
Area Dept				KT-MONTAJ 4 (1) 01
1.01				
1.02				
1.03				
1.04				
1.05				
1.06				
1.07				
1.08				
1.09				
1.10				
1.11				
1.12				
1.13				
1.14				
1.15				
1.16				
1.17				
1.18				
1.19				
1.20				
1.21				
1.22				
1.23				
1.24				
1.25				
1.26				
1.27				
1.28				
1.29				
1.30				
1.31				
1.32				
1.33				
1.34				
1.35				
1.36				
1.37				
1.38				
1.39				
1.40				
1.41				
1.42				
1.43				
1.44				
1.45				
1.46				
1.47				
1.48				
1.49				
1.50				
1.51				
1.52				
1.53				
1.54				
1.55				
1.56				
1.57				
1.58				
1.59				
1.60				
1.61				
1.62				
1.63				
1.64				
1.65				
1.66				
1.67				
1.68				
1.69				
1.70				
1.71				
1.72				
1.73				
1.74				
1.75				
1.76				
1.77				
1.78				
1.79				
1.80				
1.81				
1.82				
1.83				
1.84				
1.85				
1.86				
1.87				
1.88				
1.89				
1.90				
1.91				
1.92				
1.93				
1.94				
1.95				
1.96				
1.97				
1.98				
1.99				
2.00				



CLACK: 1.01 OPERATIF



AKYOL SAN MAKİNA A.Ş.

CALEF HUT





AKYOLSAN MAKİNA İÇ VE DİŞ TİCARET A.Ş.

TRACTOR BASKET



AKYOLSAN MAKİNA İÇ VE DİŞ TİCARET A.Ş.



AKYOLSAN MAKİNA İÇ VE DİŞ TİCARET A.Ş.





PT. KARYASAN MARINA A.S.

SHEEP FEEDING

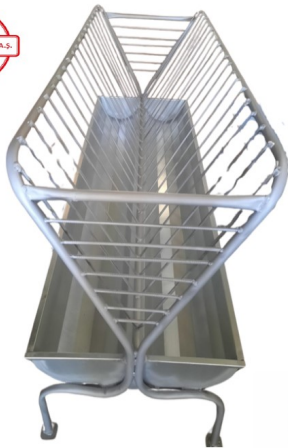

PT. KARYASAN MARINA A.S.





AHYOLSAN MARINA & YACHT CARET AS

CHAIRMAN OF THE BOARD OF DIRECTORS



KORAYAKYOL



AKYOLSAN MAKİNA İŐ VE DİŐ TİCARET AŐ.

E-Mail: info@akyolsan.com.tr

Telephone: +90 256 461 21 67

GSM: +90 542 80810 05

Website: www.akyolsan.com.tr



SRN
INTERNATIONAL MARKET
TÜRKİYE'NİN TEK SANAYİ MARKETİ

E-Mail: info@srninternationalmarket.com

GSM: +90 552 870 24 82

Website: www.srninternationalmarket.com

Adress: Umurlu Mah. Org. San. Bo/. 13. Sk. No:56/2 Efeler/AYDIN